

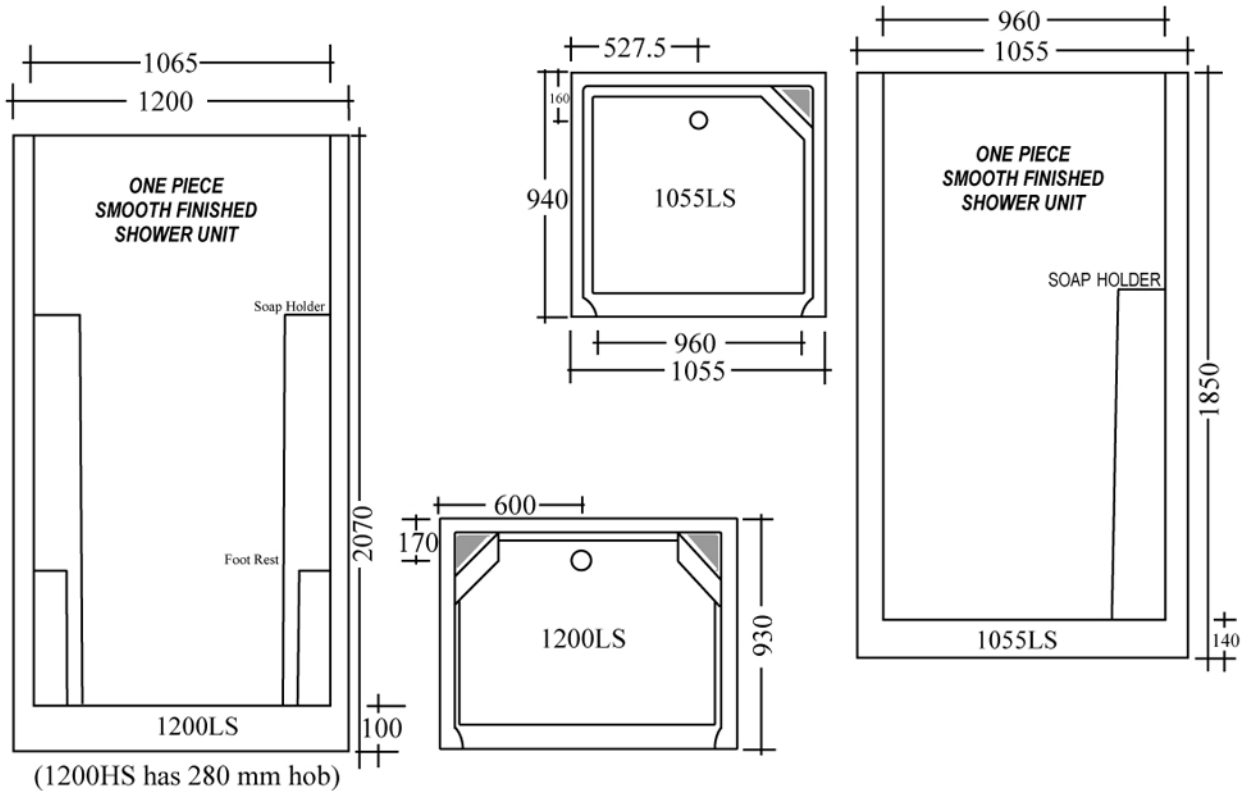

Sparkhomes.com.au

SPARK BUSINESS GROUP

Email: enquiry@sparkbusinessgroup.com.au Website: sparkhomes.com.au
 Unit 3, 13 McCormack Street, Arndell Park, 2148 NSW
 Telephone: (02) 88074717, (02) 86787856

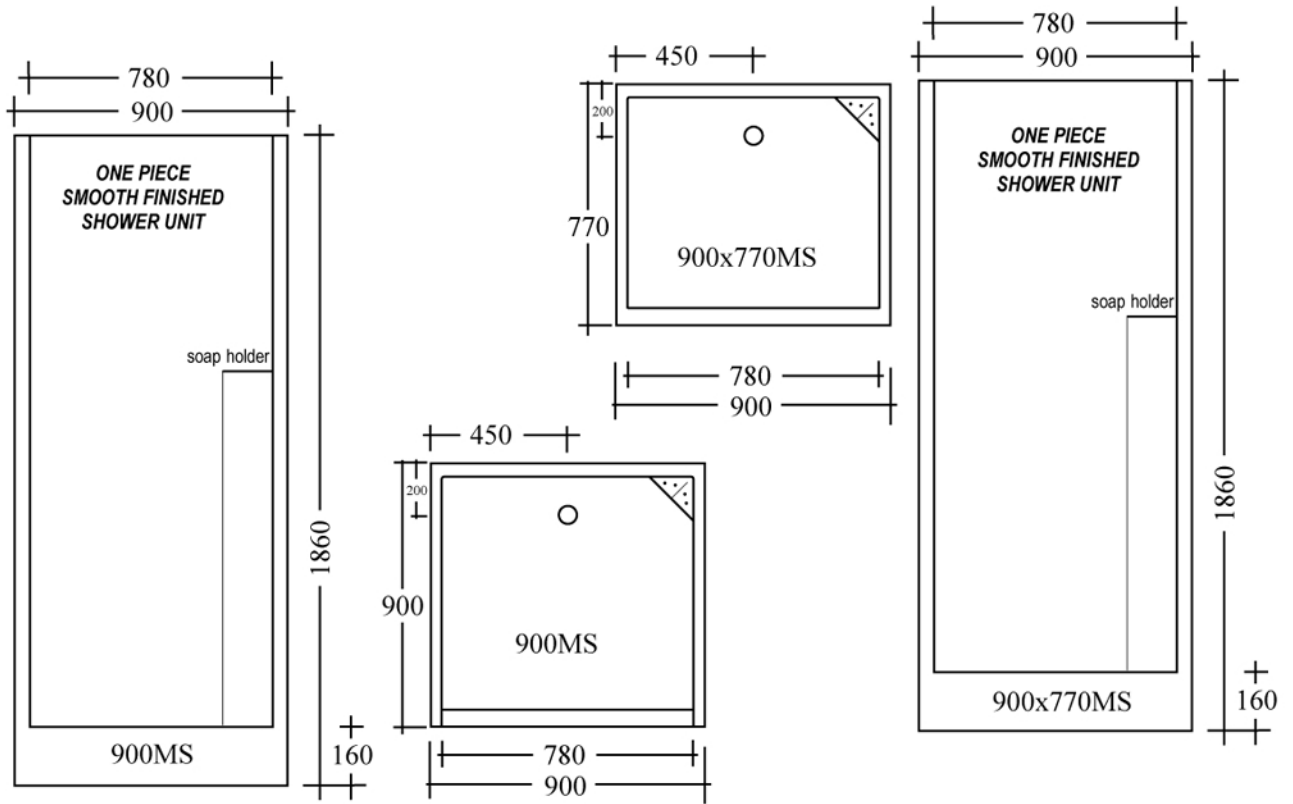

Use dimensions as a guide only.
 It is advisable to set under floor plumbing when the unit is on site.